

**SPECIFICATION****DIGITAL CAR TERRESTRIAL RECEIVER**

Revision:1.0

1.SCOPE

This specification establishes the high performance of the consumer Digital Terrestrial Receiver.

- * Fully DVB Compliant
- * Multiple Switch types supported-NTSC/PAL monitors
- * EGP
- * Dynamic FFT positioning for portable and mobile environments
- * MPEG Transport Demux and A/V Decoder
- * 32 programmable PID filters
 - One video PID
 - One audio PID
 - 30 general purpose PIDs for generic section or private PES data
- * Video Decoder
 - Real time MPEG-2 MP@ML decoding
 - Real time MPEG-4 ASP D1 resolution decoding
 - Real time MPEG-1 D1 (720 x 480 x 30 / 720 x 567 x 25) decoding
 - Advanced decoding and display control
- * Audio Decoder
 - Flexible Programmable DSP Architecture
 - Support LPCM and PCM playback
 - Support WMA™¹ playback
 - Support MPEGI/II layer 1/2/3
- * OSD
 - Multiple OSD regions with different formats
 - Support 2/4/16/256 indexed color with de-flickering
 - Support 16/24-bit direct color
- * Embedded TV encoder
 - Support 480i/576i format

2 Features

- * Installation and Set Up
 - Software upgrades via terrestrial broadcast, through USB port and Receiver to receiver
- * Display
 - 256 Color On-Screen display
 - Automatic PAL-NTSC conversion

2.1 Front End

- * Frequency range VHF 177.5 ~ 226.5MHz
 - UHF 473 ~ 858 MHz
- * Demodulation 2k / 8k COFDM
- * Compliant with ETS 300 744 (DVB-T)
- * Carrier modulation QPSK, 16-QAM, 64-QAM
- * Bandwidth 6,7,8MHz
- * Guard interval 1/32,1/16,1/8,1/4
- * FEC code rate 1/2,2/3,3/4,5/6,7/8

SPECIFICATION

DIGITAL CAR TERRESTRIAL RECEIVER

Revision:1.0

2.2 Audio

- * Mode Stereo, Dual, Joint Stereo and Mono
- * Audio Format MPEG-2 Layer 1 and Layer 2 , Dolby Digital, MP3, and Linear PCM (LPCM)
- * Output Connection 1 Set RCA Jack For Base Band
- * Volume Control Stepping Adjustment

2.3 Video

- * Connector Type RCA Jack
- * Video Format MPEG-2 MP@ML ISO 13818-2
- * Frame rate NTSC : 30 PAL : 25
- * Display Pixel NTSC 720 * 480 PAL 720 * 576
- * Aspect Ratio 16 : 9 or 4:3

2.4 Interface

- * Support USB2.0 DISK FAT format only
- * Power switch

2.5 Front panel

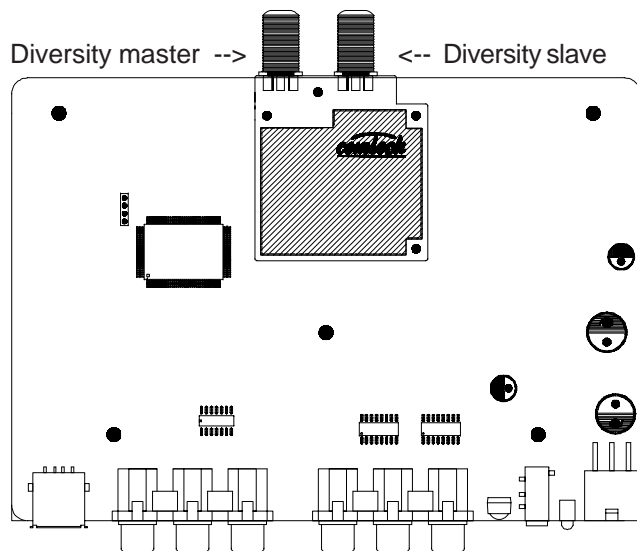

2.6 Rear panel

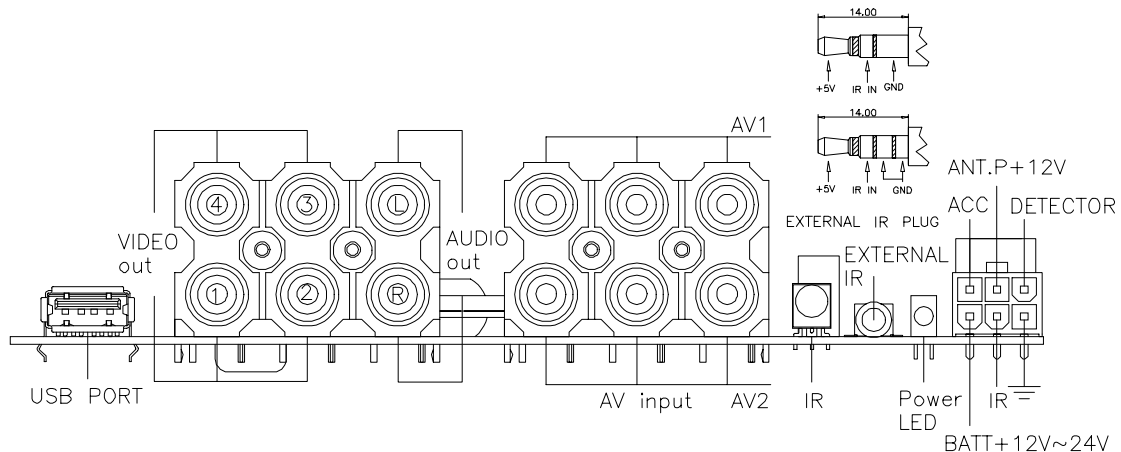



SPECIFICATION						
DIGITAL CAR TERRESTRIAL RECEIVER					Revision:1.0	
NO	ITEM	CONDITION	MIN.	TYP.	MAX.	NOTES
3	Front End Electrical characteristics					
3.1	C / N in AWGN 6MHz, G1/4,RF=-50dBm RS uncorrected error=0	8K 64QAM R7/8		21		dB
		8K 64QAM R2/3		17.2		dB
		8K 64QAM R1/2		15		dB
		8K 16QAM R3/4		13.1		dB
		8K 16QAM R2/3		11.6		dB
		8K QPSK R1/2		3.6		dB
3.3	Sensitivity in AWGN 6MHz, GI=1/4 RS uncorrected error=0	8K 64QAM R7/8		-73.5		dBm
		8K 64QAM R2/3		-77.5		dBm
		8K 64QAM R1/2		-81.5		dBm
		8K 16QAM R3/4		-82.5		dBm
		8K 16QAM R2/3		-85.5		dBm
		8K QPSK R1/2		-92.5		dBm
3.4	C / N in 0dB Echo 6MHz 581MHz,G1/4,RF=-50dBm Crition:Picture Quality	8K 64QAM R3/4		26.1		dB
		8K 64QAM R2/3		21.7		dB
3.5	Frequency Offset	8K 6MHz 64QAM R2/3	-250		+250	KHz
		G1/8 -60dBm				
3.6	Mobile Performance RF Level=-50dBm,581MHz 6MHz, C/N=OFF Average Packet Error Rate < 5x10 ⁻³	2K 16QAM R3/4,GI=1/4		300		Km
		8K 16QAM R2/3,GI=1/4		120		Km
		8K 64QAM R/2/3,GI=1/4		80		Km
3.7	RF Max Input Level 6MHz GI=1/4 RS uncorrected error=0	8K 64QAM R7/8		-25		dB
		8K 16QAM R2/3		-10		

SPECIFICATION

DIGITAL CAR TERRESTRIAL RECEIVER
Revision:1.0

4. Diversity Electrical Specification (Doppler Performance)

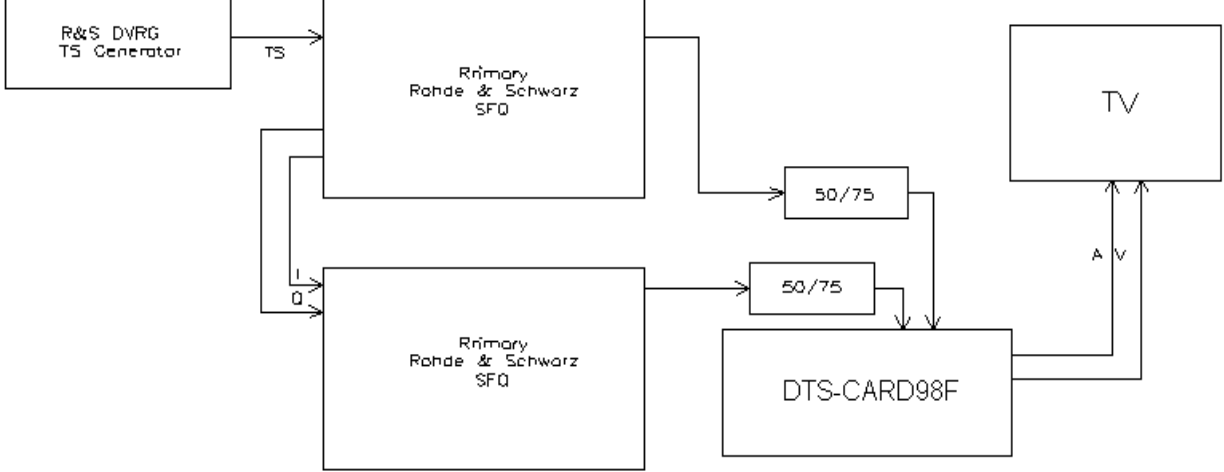

Fading and Doppler Test Equipment Setup

Typical Urban reception (TU6)

This profile reproduces the terrestrial propagation in an urban area. It has been defined by COST207 as a Typical Urban (TU6) profile and is made of 6 paths having wide dispersion in delay and relatively strong power. **[Reference 1]**

Tap number	Delay (us)	Power (dB)	Doppler spectrum
1	0.0	-3	Rayleigh
2	0.2	0	Rayleigh
3	0.5	-2	Rayleigh
4	1.6	-6	Rayleigh
5	2.3	-8	Rayleigh
6	5.0	-10	Rayleigh

Typical Urban profile (TU6) constitution

SPECIFICATION																																												
DIGITAL CAR TERRESTRIAL RECEIVER	Revision:1.0																																											
<p>Rural Area reception (RA6)</p> <p>This profile reproduces the terrestrial propagation in a rural area. It has been defined by COST207 as a Rural Area (RA6) profile and is made of 6 paths having relatively short delay and small power. [Reference 1]</p> <table border="1" style="margin-left: auto; margin-right: auto; border-collapse: collapse;"> <thead> <tr> <th>Tap number</th> <th>Delay (us)</th> <th>Power (dB)</th> <th>Doppler spectrum</th> </tr> </thead> <tbody> <tr> <td style="text-align: center;">1</td> <td style="text-align: center;">0.0</td> <td style="text-align: center;">0</td> <td style="text-align: center;">Rice</td> </tr> <tr> <td style="text-align: center;">2</td> <td style="text-align: center;">0.1</td> <td style="text-align: center;">-4</td> <td style="text-align: center;">Rayleigh</td> </tr> <tr> <td style="text-align: center;">3</td> <td style="text-align: center;">0.2</td> <td style="text-align: center;">-8</td> <td style="text-align: center;">Rayleigh</td> </tr> <tr> <td style="text-align: center;">4</td> <td style="text-align: center;">0.3</td> <td style="text-align: center;">-12</td> <td style="text-align: center;">Rayleigh</td> </tr> <tr> <td style="text-align: center;">5</td> <td style="text-align: center;">0.4</td> <td style="text-align: center;">-16</td> <td style="text-align: center;">Rayleigh</td> </tr> <tr> <td style="text-align: center;">6</td> <td style="text-align: center;">0.5</td> <td style="text-align: center;">-20</td> <td style="text-align: center;">Rayleigh</td> </tr> </tbody> </table> <p style="text-align: center;">Table 2: Rural Area profile (RA6) constitution</p> <p>0dB Echo with Doppler</p> <p>This profile has been defined by member of the Motivate group. The 0dB echo profile is then made of two rays having the same power, delayed from half the Guard Interval value and presenting a pure Doppler characteristic. The Doppler frequency f_d is defined to be half the frequency separation of the two paths. [Reference 1]</p> <table border="1" style="margin-left: auto; margin-right: auto; border-collapse: collapse;"> <thead> <tr> <th>Tap number</th> <th>Delay (us)</th> <th>Power (dB)</th> <th>Doppler spectrum</th> <th>Frequency ratio</th> </tr> </thead> <tbody> <tr> <td style="text-align: center;">1</td> <td style="text-align: center;">0</td> <td style="text-align: center;">0</td> <td style="text-align: center;">Pure Doppler</td> <td style="text-align: center;">-1</td> </tr> <tr> <td style="text-align: center;">2</td> <td style="text-align: center;">$1/2 T_g$</td> <td style="text-align: center;">0</td> <td style="text-align: center;">Pure Doppler</td> <td style="text-align: center;">+1</td> </tr> </tbody> </table> <p style="text-align: center;">Table 3: 0 dB echo with Doppler profile constitution</p>		Tap number	Delay (us)	Power (dB)	Doppler spectrum	1	0.0	0	Rice	2	0.1	-4	Rayleigh	3	0.2	-8	Rayleigh	4	0.3	-12	Rayleigh	5	0.4	-16	Rayleigh	6	0.5	-20	Rayleigh	Tap number	Delay (us)	Power (dB)	Doppler spectrum	Frequency ratio	1	0	0	Pure Doppler	-1	2	$1/2 T_g$	0	Pure Doppler	+1
Tap number	Delay (us)	Power (dB)	Doppler spectrum																																									
1	0.0	0	Rice																																									
2	0.1	-4	Rayleigh																																									
3	0.2	-8	Rayleigh																																									
4	0.3	-12	Rayleigh																																									
5	0.4	-16	Rayleigh																																									
6	0.5	-20	Rayleigh																																									
Tap number	Delay (us)	Power (dB)	Doppler spectrum	Frequency ratio																																								
1	0	0	Pure Doppler	-1																																								
2	$1/2 T_g$	0	Pure Doppler	+1																																								

**SPECIFICATION****DIGITAL CAR TERRESTRIAL RECEIVER**

Revision:1.0

Results**Typical Urban Reception (TU6) Results**

The following results are the Doppler Frequency to achieve the point of failure of 1 picture artefact or error in a 20 second time period.

Modulation Mode	typ
8K 64QAM, FEC 1/2 and Guard Band 1/8	45Hz
8K 64QAM, FEC 2/3 and Guard Band 1/8	26Hz
2K 64QAM, FEC 2/3 and Guard Band 1/32	128Hz
2K 16QAM, FEC 3/4 and Guard Band 1/32	195Hz

Rural Area Reception (RA6) Results

The following results are the Doppler Frequency to achieve the point of failure of 1 picture artefact or error in a 20 second time period.

Modulation Mode	typ
8K 64QAM, FEC 1/2 and Guard Band 1/8	30Hz
8K 64QAM, FEC 2/3 and Guard Band 1/8	20Hz
2K 64QAM, FEC 2/3 and Guard Band 1/32	86Hz
2K 16QAM, FEC 3/4 and Guard Band 1/32	119Hz

0dB Echo With Doppler Reception (0dB) Results

The following results are the Doppler Frequency to achieve the point of failure of 1 picture artefact or error in a 20 second time period.

Modulation Mode	typ
8K 64QAM, FEC 1/2 and Guard Band 1/8	50Hz
8K 64QAM, FEC 2/3 and Guard Band 1/8	43Hz
2K 64QAM, FEC 2/3 and Guard Band 1/32	160Hz
2K 16QAM, FEC 3/4 and Guard Band 1/32	233Hz

SPECIFICATION					
DIGITAL CAR TERRESTRIAL RECEIVER				Revision:1.0	
5. Video Electrical Characteristics					
Signal Performance at CVBS output (4 x RCA)					
	Condition	Min.	Typ.	Max.	Unit
Bar level(NTSC)		90	100	110	IRE
Bar level(PAL)		630	700	770	mV
Sync level(NTSC)		38	40	42	IRE
Sync level(PAL)		280	300	315	mV
Burst amplitude(NTSC)		38	40	42	IRE
Burst amplitude(PAL)		280	300	315	mV
Picture Sync ratio		95	100	105	%
Line time distortion				1	%
C/L gain		80		120	%
C/L delay		-40		40	ns
K-2T				2.5	%
D.G.			2.8	5	%
D.P.			2.5	5	Deg
S/N ratio		55	56		dB
S/N ratio(Unweighted)			61		dB
Impedance	RCA Jack		75		ohm
Output voltage	DC coupled	0.8	0.9	1.0	Vp-p
NOTE: video 75 ohm load					
5.1 Audio Electrical Characteristics					
2 separate audio outputs, left and right channels, are supported (2 x RCA).					
	Condition	Min.	Typ.	Max.	Unit
S/N ratio L		70			dB
S/N ratio R		70			dB
THDL				1	%
THDR				1	%
Amplitude freq. response				2	dB
L-R level difference				1	dB
Output level		0.9	1	1.1	Vp-p
Output impedance(unbalanced)			600		ohm
Audio Separation	Vin=0.5RMS	70			dB
R & L of TV output	R=1kohm,gain=0dB	70			dB

SPECIFICATION

DIGITAL CAR TERRESTRIAL RECEIVER

Revision:1.0

5.2 Environmental requirement

Operating temperature 0°C to 50°C
 Storage temperature -40°C to 85°C

5.3 Power

DC input
 DC voltages input 10~24VDC
 Power consumption 4.5W max (auxiliary power off)
 Auxiliary power 12V 200mA max (output voltages 10.5~12.5VDC)
 Antenna power 5V 30mA max

5.4 Microprocessor

Microprocessor SUNPLUS SPHE1002A
 Clock 147.456MHz
 SDRAM 64Mbit
 Flash memory 16Mbit

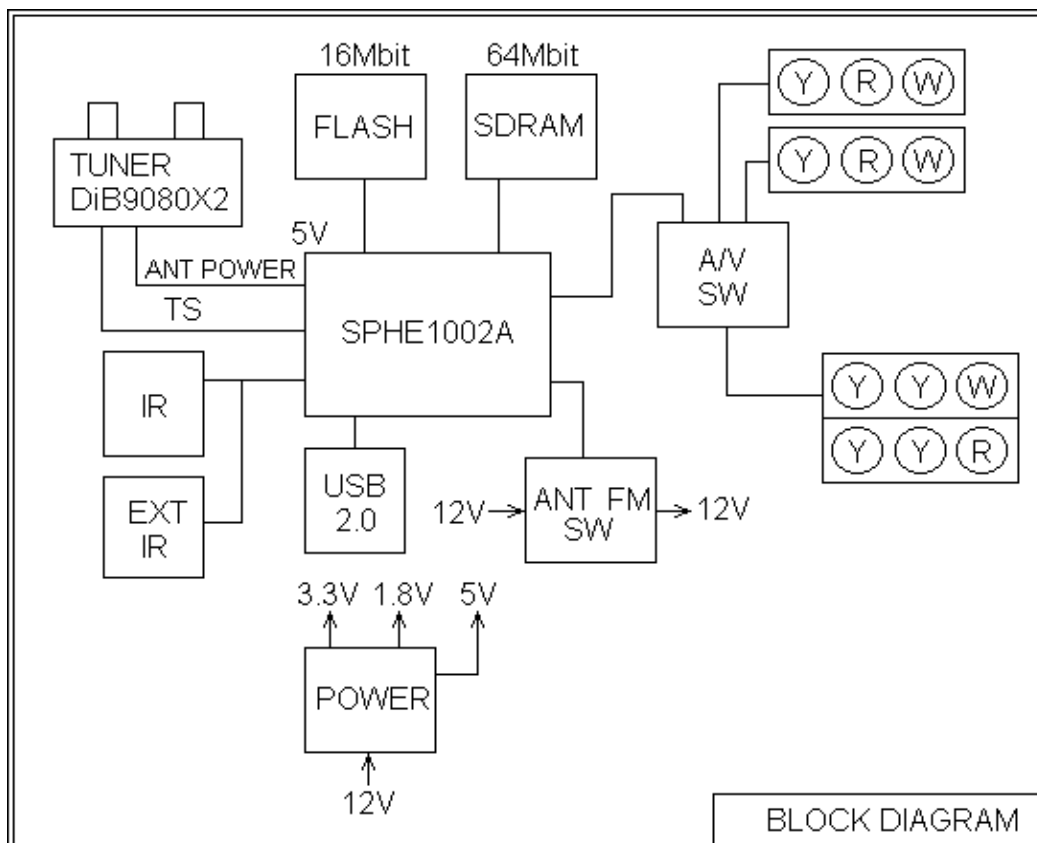

**SPECIFICATION****DIGITAL CAR TERRESTRIAL RECEIVER**

Revision:1.0

6. Electrostatic discharge**6.1 Test**

Each front-end must be capable of normal performance following its subjection to the following tests:

MIL STD 883C HBM

Test is performed with a voltage discharge from a 100 **PF** capacitor over a 1500 **OHM** series resistance in the discharge path. There is a direct contact between the test probe head and the unit under test, using the test points and conditions detailed below:

- o Test to AV1 in And AV2 VIDEO out :
3 successive ESD discharges of **+/-2 KVDC** between each pin and the front-end frame.

IEC 1000-4-2

Test is performed with a voltage discharge from a 150 **PF** capacitor over a 330 **OHM** series resistance in the discharge path. There is a direct contact between the test probe head and the unit under test, using the test points and conditions detailed below:

- o Test for antenna input socket **+/-8 KVDC**

SPECIFICATION**DIGITAL CAR TERRESTRIAL RECEIVER**

Revision:1.0

7 Reliability test procedure & conditions

Note:Room temperature = 25°C +/- 2°C

7.1 Heat load test

- o Measure the DUTs at room temperature
- o Load the DUTs into chamber of the following conditions:

Temperature = 60 °C
Period = 500 hrs
Cycle = 1.5 hrs on; 0.5 hrs off
Quantity = 10 pcs

- o Cool-down 0,5 hr at room temperature, then measured the DUTs within 1 hr
- o The test shall be continued to 1000 cycles for information only

7.2 Humidity load test

- o Measure the DUTs at room temperature
- o Load the DUTs into chamber of the following conditions:

Temperature = 40 +/- 5 °C
Period = 24 hrs
Cycle = constantly on
Quantity = 24 pcs

- o Cool-down 0.5 hr at room temperature, then measured the DUTs within 1 hr
- o Load the DUTs again into chamber of following conditions:

Temperature = 40+/-5°C
Humidity = 90 to 95%
Period = 500 hrs
Cycle = 1.5 hrs on; 0.5 hrs off
Quantity = 20 pcs

- o Cool down 0.5hr at room temperature, then measured the DUTs within 1 hr

SPECIFICATION**DIGITAL CAR TERRESTRIAL RECEIVER**

Revision:1.0

7.3 Cold test

- o Measure the DUTs at room temperature
- o Load the DUTs into chamber of the following conditions:

Temperature = -2 +/-5 °C
Period = 500 hrs
Cycle = constantly on
Quantity = 10 pcs

- o Warm up for 2 hrs at room temperature, then measured the DUTs within 1 hr

7.4 Thermal shock

- o Measure the DUTs at room temperature
- o Load the DUTs into chamber of the following conditions:

Temperature = -25°C for 60 min
 ↓ ↑
 80°C for 60 min
Period = 200 cycles
Power = power off
Quantity = 10 pcs

- o Cool-down 0.5 hr at room temperature then measured the DUTs within 1 hr

7.5 Temperature cycle test

- o Measure the DUTs at room temperature
- o Load the DUTs into chamber of the following conditions:

Temperature = -5°C for 16 hrs then 60°C for 8 hrs
Period = 500 hrs
Cycle = constantly on
Quantity = 10pcs

- o Cool down 0.5 hr at room temperature, then measured the DUTs within 1 hr
- o Load the DUTs again into chamber of the following conditions:

Temperature = 40 +/- 5°C
Humidity = 90 to 95%
Period = 500 hrs
Cycle = 1.5 hrs on; 0.5 hrs off
Quantity = 10 pcs

- o Cool down 0.5 hr at room temperature, then measured the DUTs within 1hr

SPECIFICATION**DIGITAL CAR TERRESTRIAL RECEIVER**

Revision:1.0

7.6 Vibration test

- o Frequency: 3.5 Hz
- o Vertical amplitude: 15 to 25 mm
- o Duration: 1 hr
- o Quantity: 1 carton

7.7 Drop test

- o Packaged apparatus: <or = 50 kg
- o Height: depend on weight
- o 1 corner + 3 edger + 6 faces

Drop on the weakest corner (point G)

Drop on the shortest edge on contact with point G

Drop on average edge in contact with point G

Drop on the longest edge in contact with point G

Drop flat wise on the side of minimum surface

Drop flat wise on the side of opposite minimum surface

Drop flat wise on the side of average surface

Drop flat wise on the side of opposite average surface

Drop flat wise on the side of maximum surface

Drop flat wise on the side of opposite maximum surface

- o Quantity :1 carton

7.8 Life test

- o Measure the DUTs at room temperature
- o Load the DUTs into chamber of the following conditions:

Temperature = 60 °C

Period = 500 hrs

Cycle = constantly on

Quantity = 20 pcs

- o Cool down 0.5 hr at room temperature, then measured the DUTs within 1hr

SPECIFICATION

DIGITAL CAR TERRESTRIAL RECEIVER

Revision:1.0

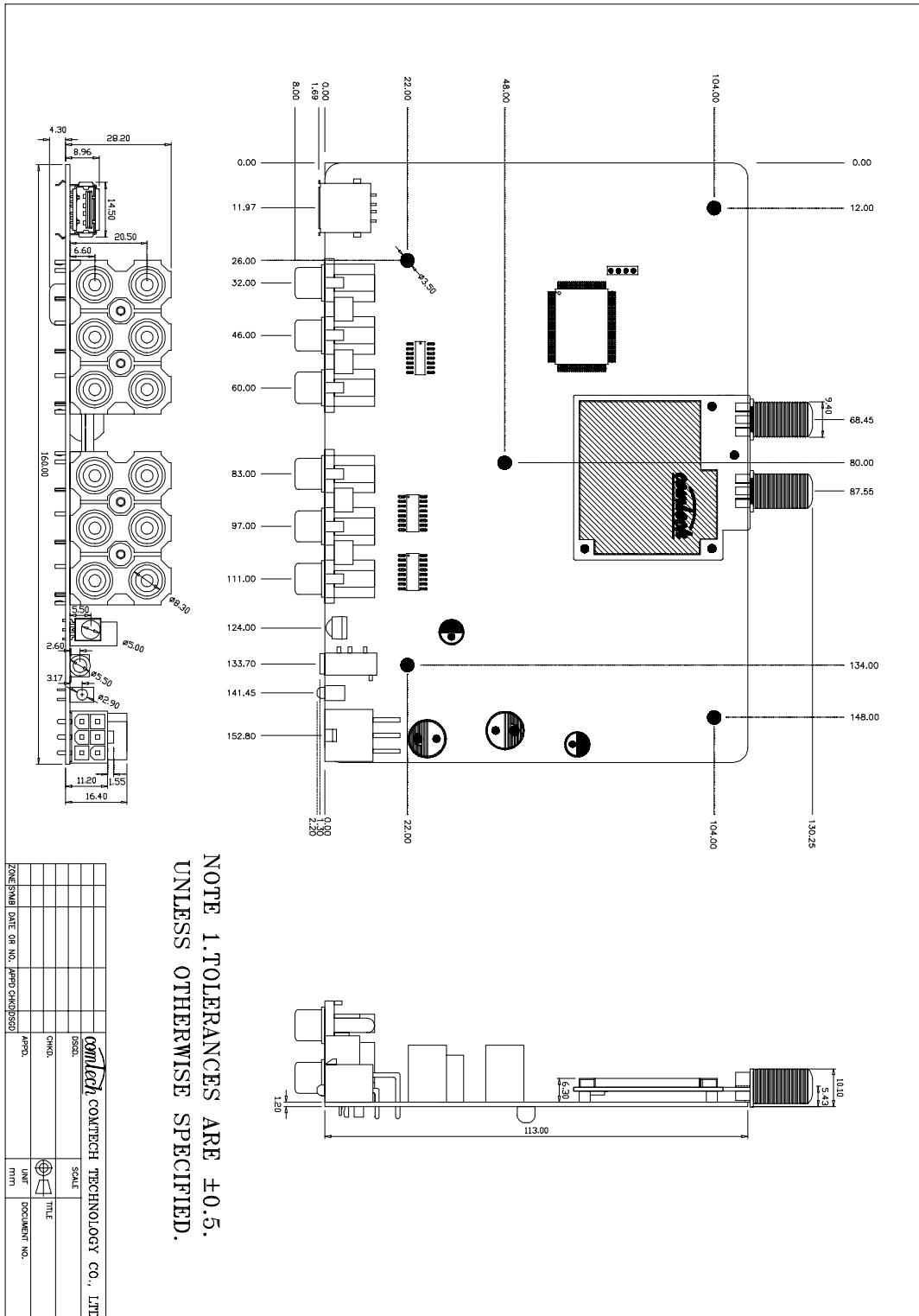

ZONE/SM/ DATE OR NO.	DATE OR NO.	APPRO. CHANGED	SCALE	TITLE	DOCUMENT NO.
COMTECH TECHNOLOGY CO., LTD.					
DESIGN	CHKD.	APPR.	DATE		